

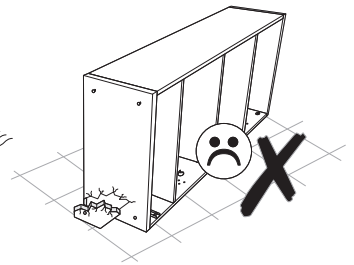

SANTA FE 89-180-A,B

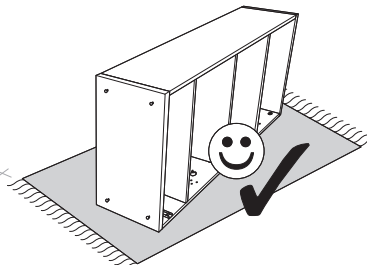

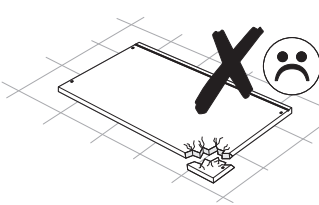
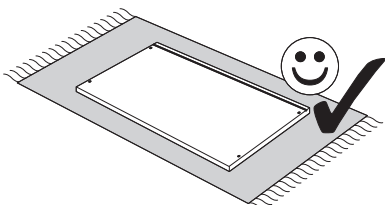
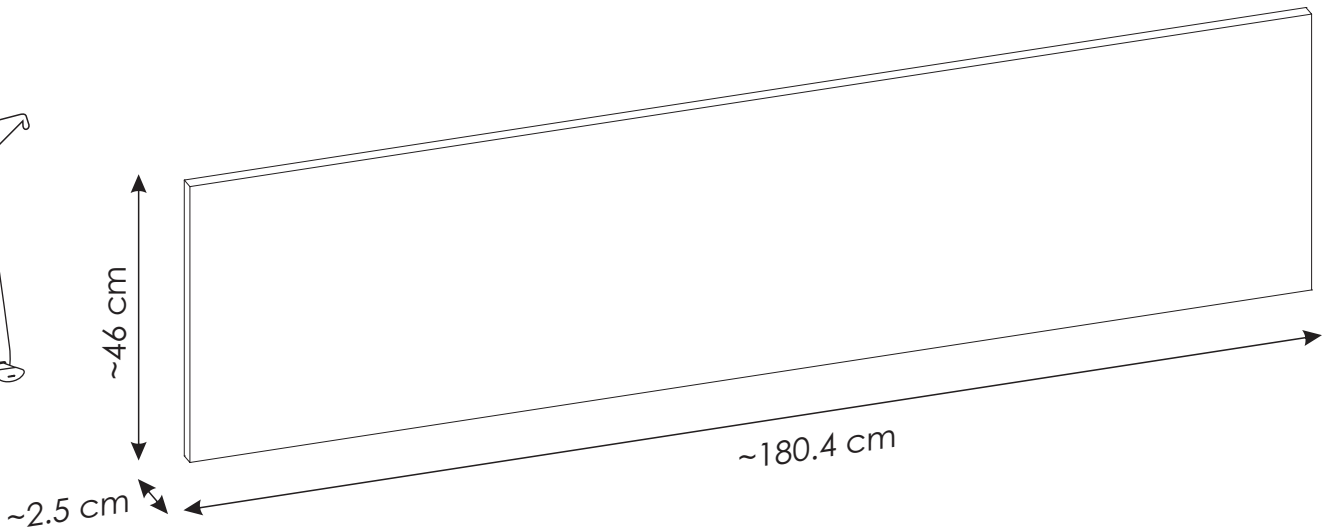
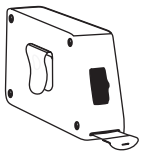
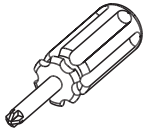
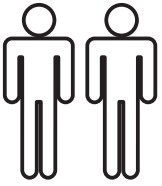
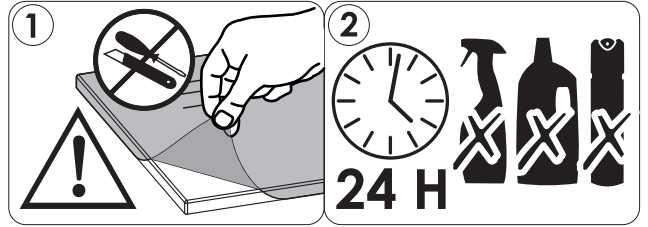
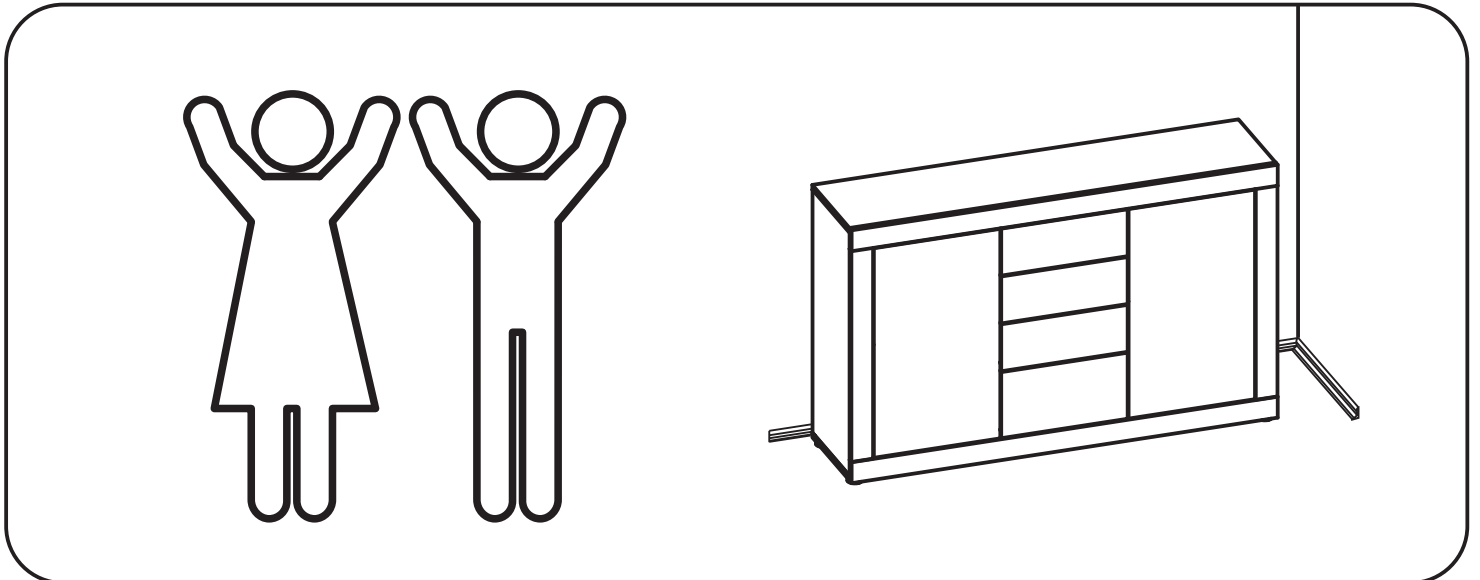
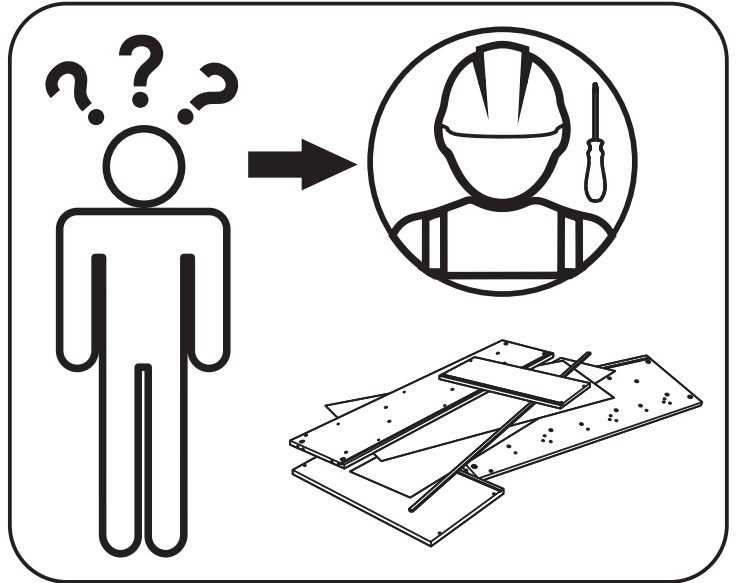
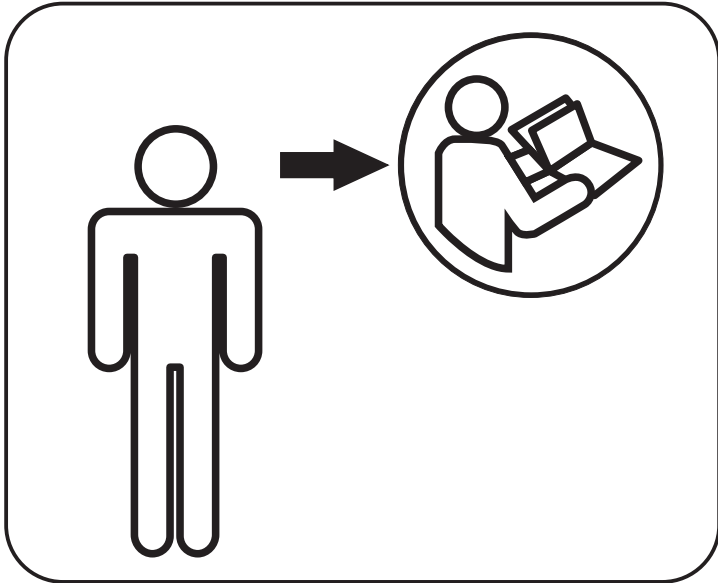
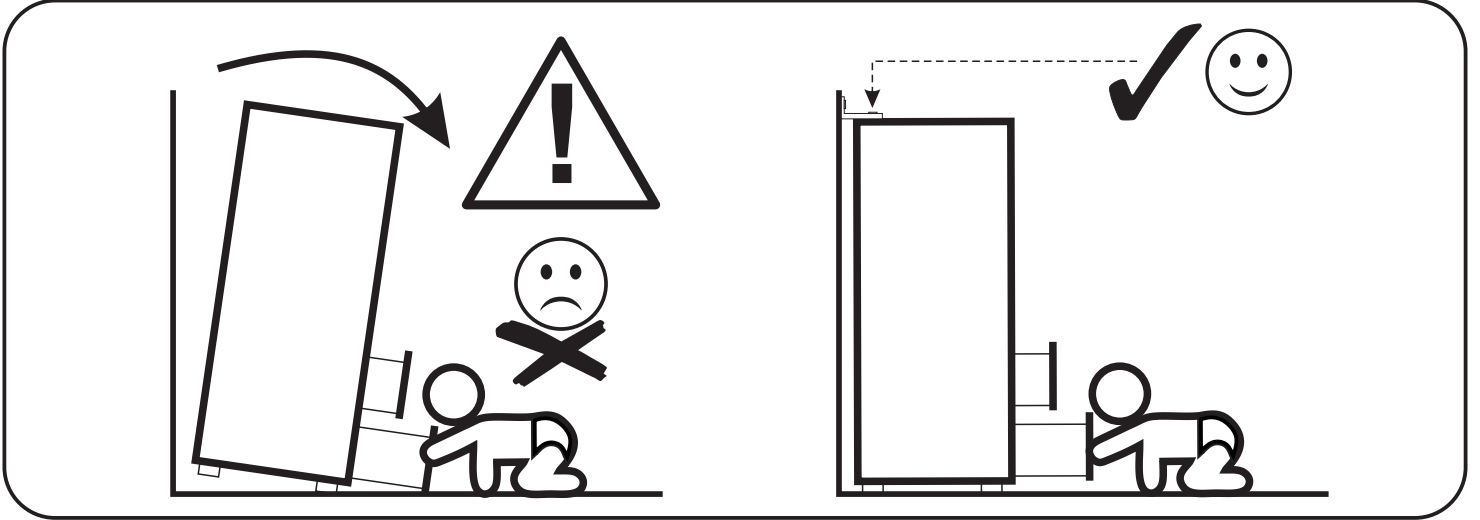
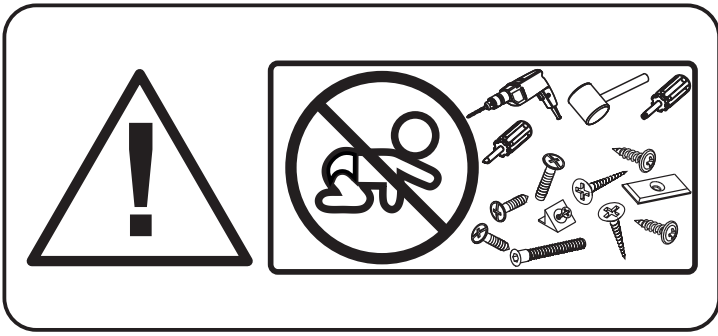
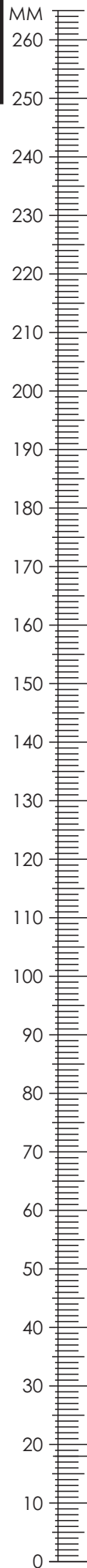

SANTA FE 89-180-A,B



N5	3,5 x 16 mm	x36	Q8		x18
-----------	-------------	-----	-----------	---	-----

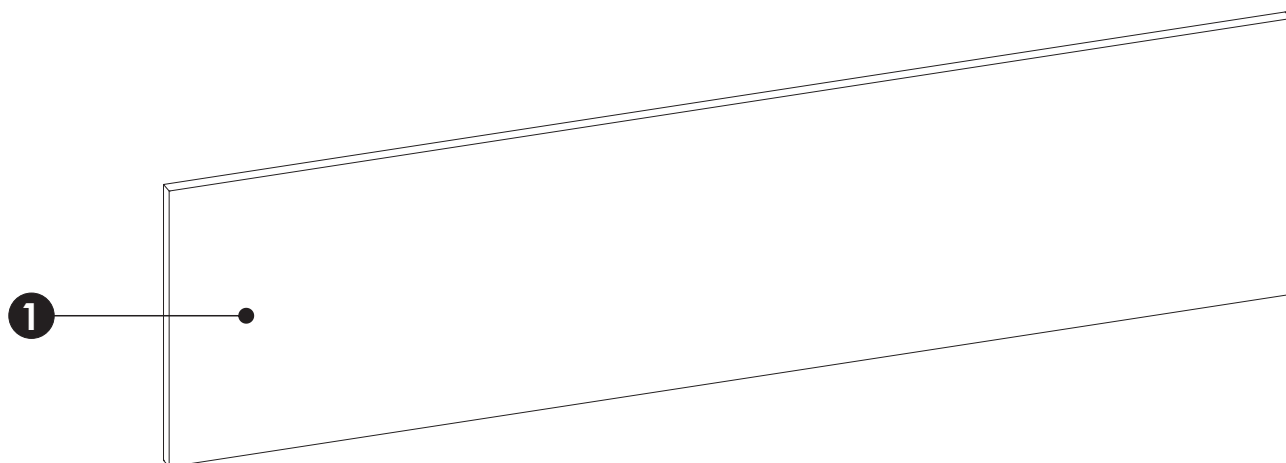

1	1804	460	25	x1	1/1
----------	------	-----	----	----	-----



1 ▶

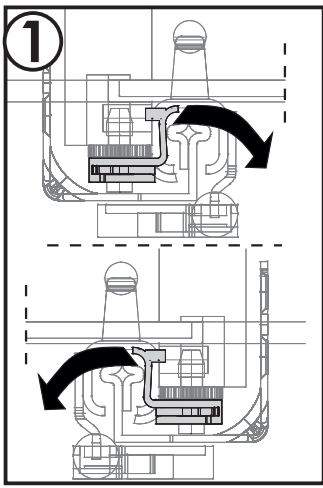

x2

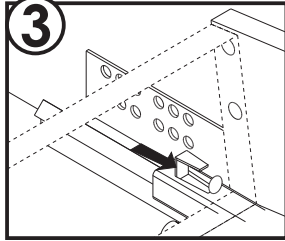
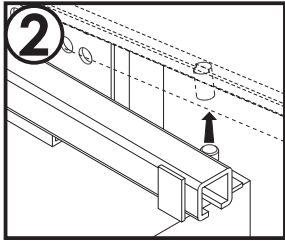
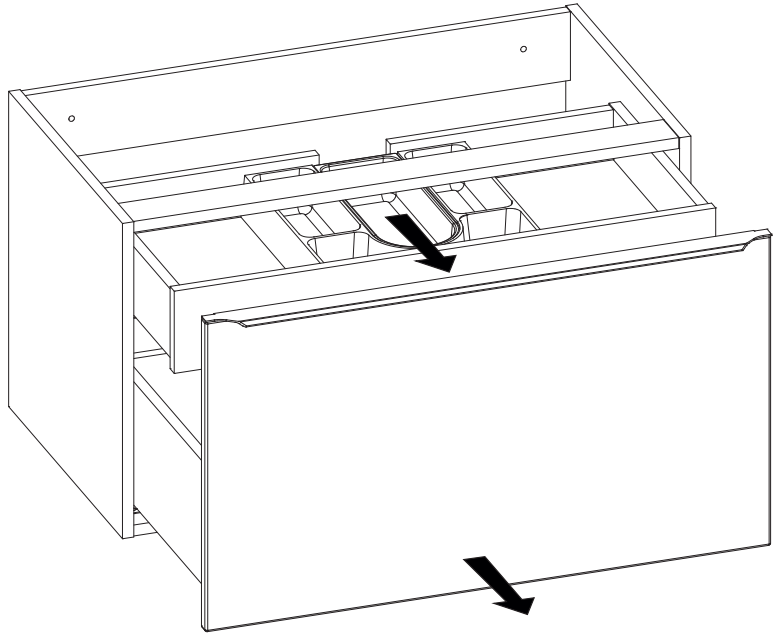

2 ▶

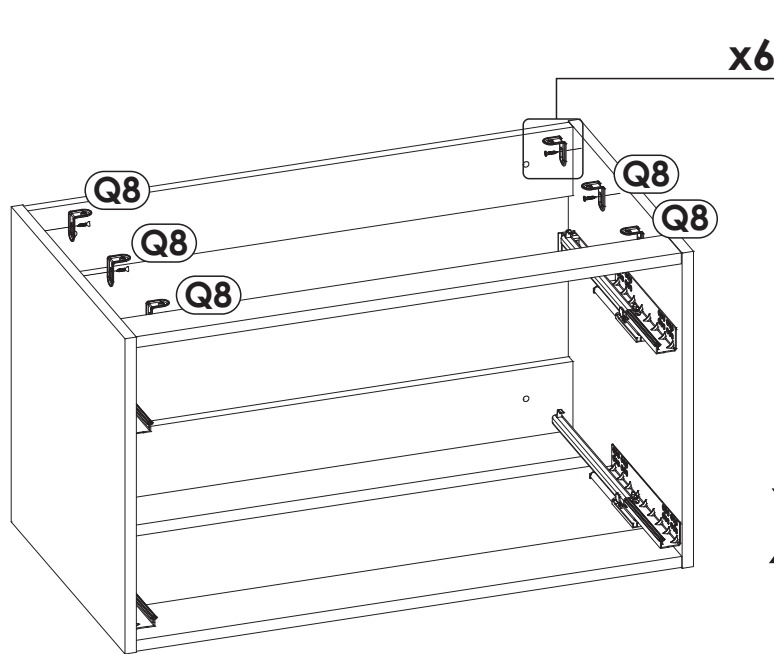
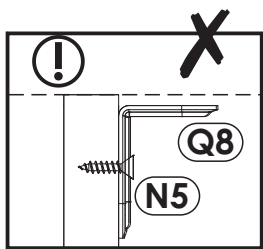
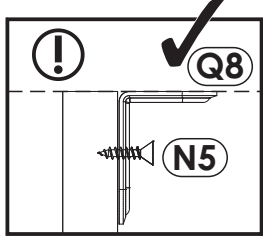

x2

3 ▶

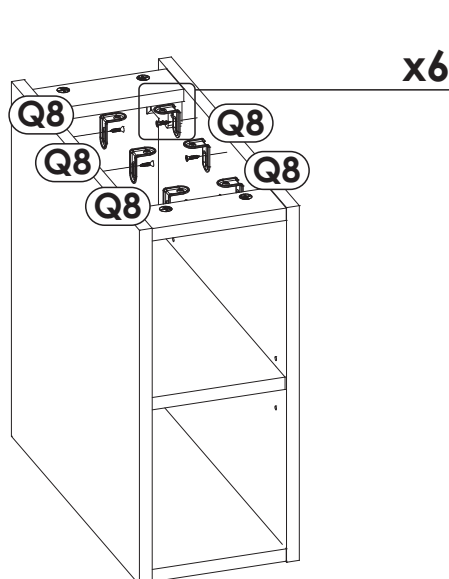
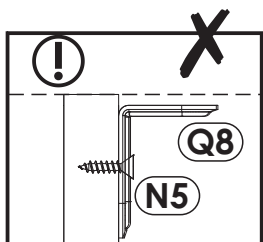
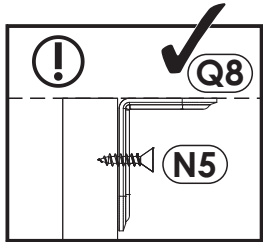

4 ▶ A.

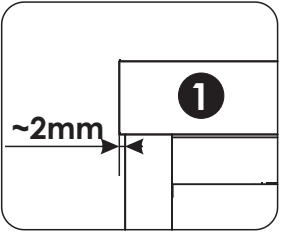
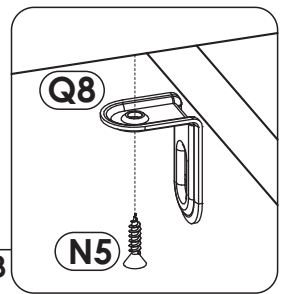
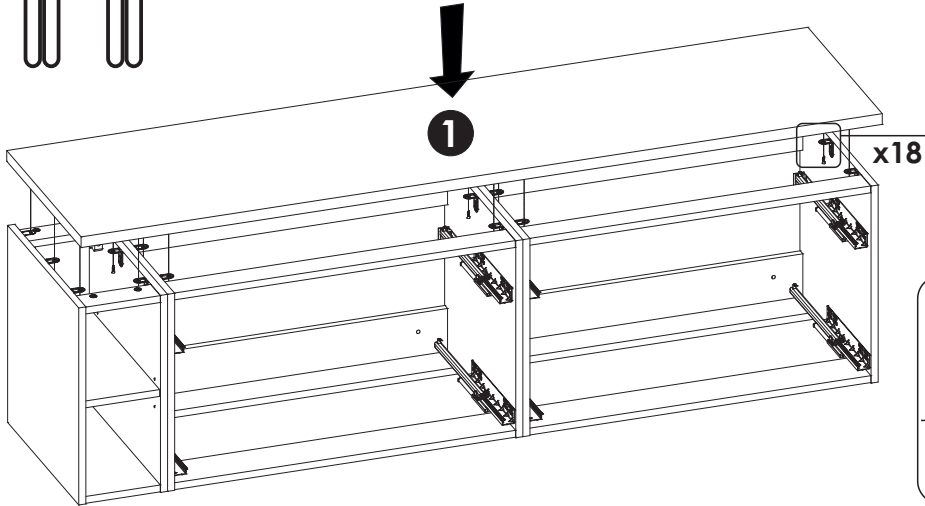
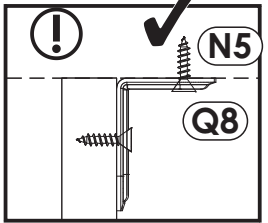
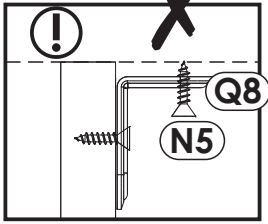
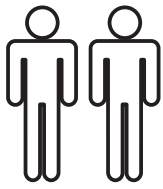

B.

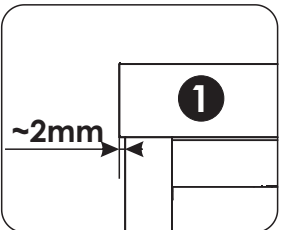
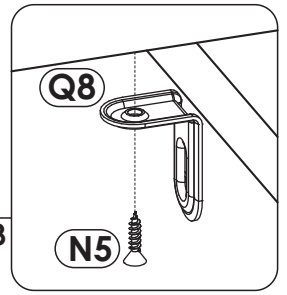
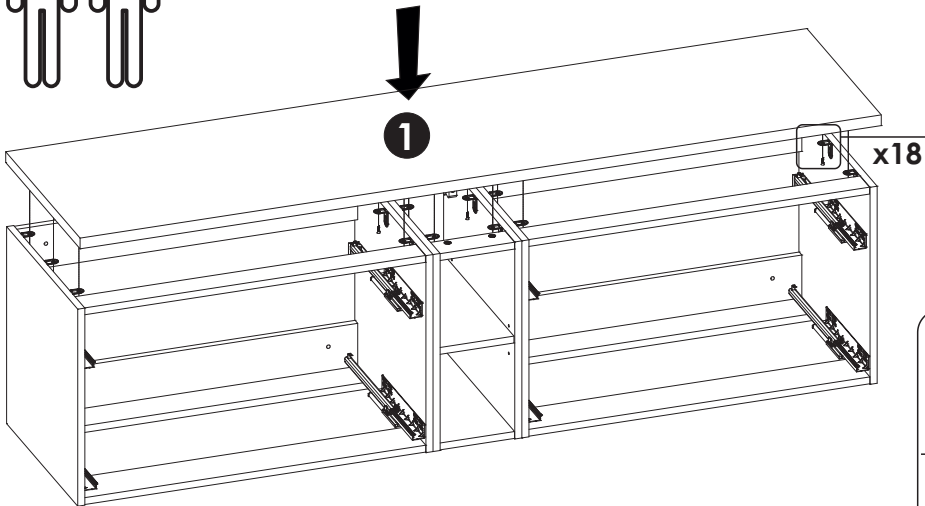
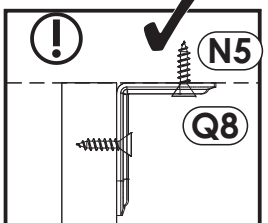
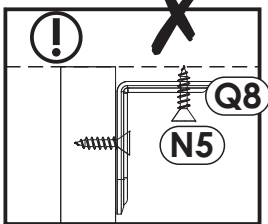
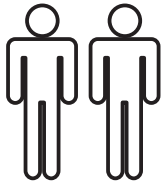

C.

